

The logo consists of a white rectangular box containing the text 'KETLEY' in white on a dark blue background, 'BRICK' in white on a brown background, and 'Bricks, Slips and Pavers' in black on a white background. The background of the entire page is a photograph of a paved walkway with a diamond-patterned brick paver design.

KETLEY

BRICK

Bricks, Slips and Pavers

Ketley Brick Clay Pavers, Quarry Tiles and Fittings

Ketley Brick Company Ltd
Dreadnought Works, Pensnett, Brierley Hill, West Midlands, DY5 4TH

Tel: 01384 78361 Fax: 01384 74553 Email: info@ketley-brick.co.uk Web: www.ketley-brick.co.uk

Contents

SECTION	PAGE
RIGID PAVEMENT CONSTRUCTION	3
FLEXIBLE PAVEMENT CONSTRUCTION	4, 5, 6
ADDITIONAL LAYING REQUIREMENTS	7
BASIC BOND PATTERNS	8
PATTERNED PAVERS	9
PAVER FITTINGS	
- TACTILE PAVER UNITS	10
- STARTER UNITS	11
- KERB UNITS	12, 13
- DRAINAGE UNITS	14
- TRANSITION UNITS	15
- STEP PAVERS	15
- DETERRENT PAVERS	15
PAVING SPECIFICATION	16
KETLEY QUARRY TILES	17
LAYING QUARRY TILES	18
QUARRY TILES FITTINGS	19
QUARRY TILES SPECIFICATION	20

INTRODUCTION

Ketley Brick Company has made pavers and Staffordshire Blue bricks in Brierley Hill for over a century. Our modern plant is quality assured to ISO 9001:2008 and we operate an Environmental Management System accredited to ISO 14001:2004.

The Etruria marl used in manufacture and burnt to over 1150°C produces material of unrivalled strength and durability in rich distinctive colours that are permanent. Clay colours do not fade.

In a modern environment Ketley pavers feature in pedestrianisation schemes, urban renewal, dockland redevelopment and petrol station forecourts. In an historic context Ketley pavers can be seen in the current restoration of large parts of the canal system where Ketley materials provide a seamless match to the original Victorian brickwork. We offer a number of traditional sizes and Ketley pavers are also suitable

in engineering applications where resistance to acids, alkalis and abrasion is desirable.

Ketley's Victorian pattern pavers - diamond chequer, 8 panel and 2 panel pavers - provide scope for specifiers in breaking up larger more mundane areas of paving.

Long experience in the production of special brick fittings has now been applied to the growing demand for special paver fittings - road humps for traffic calming systems and tactile and deterrent pavers for pedestrian management systems.

Our experienced representatives value the opportunity to be included in design discussions. Simplification of design can often lead to significant savings, whilst retaining the designer's essential requirements.

RIGID PAVEMENT CONSTRUCTION

Rigid fixing of pavers is the traditional method of laying and offers benefits in certain applications. The mortar joint can be used to complement or contrast adjacent brickwork. The joints can be used as a feature by the use of coloured mortars. It can also provide structural strength in areas subject to high volumes of water or frequent high pressure water hosing.

BASE REQUIREMENTS

Generally the base for rigid paving will be concrete, either plain or reinforced. The composition and thickness is dependent on structural design considerations but typically will be 100-150mm thick.

PAVERS

The Standard covering the technical specification for Pavers for rigid laying is EN 1344:2002 Clay Pavers-Requirements and Test Methods. There are however no design guidelines within the Standard. Design ideas can be found on pages 8 & 9 of this brochure.

MORTARS

When pavers are fixed rigidly the mortars used for jointing and bedding must have a sufficiently low permeability and adequate cement content to ensure good frost resistance.

In general only 1 : 3 cement : sand mix, or 1 : 1/4 : 3 cement : lime : sand should be used.

It is recommended that a tooled, slightly dished joint profile referred to as "bucket handle" is specified. This method helps to seal the surface of the joints and presses the mortar against the pavers.

MOVEMENT JOINTS

When pavers are laid in the rigid format it is essential to provide adequate movement joints. Perimeter joints should be provided around rigid paved areas if any dimension of the paved area exceeds 6 metres, and thereafter at approximately 6 metre intervals. In addition movement joints should be provided around fixed points of restraint such as manhole covers, columns and upstands. Where there is a movement joint in the concrete base this should be carried through to the surface. Movement joints are usually 10mm wide and should comprise of a compressible joint filler, such as polyethylene foam, a barrier (or joint breaker) and an extensible tack free sealant.



Brown Brindle Square Edged Pavers in running bond with plain Blue Square Edged Pavers at Canalside, Welshpool.

CLEANING

During construction great care must be taken to avoid cement staining of the paver faces. Any cement or lime stains may be removed by the careful use of proprietary brickwork cleaners which are based on dilute hydrochloric acid solution. These should be used in accordance with the manufacturer's health and safety recommendations. It is important to saturate the surface with clean water before applying cleaning agents.

A rigid pavement does not become fully mature for approximately 28 days after laying. Therefore it is recommended that trafficking must be delayed until after that time.

For external paving sweeping is the only "routine" maintenance required but in damp and shaded areas a suitable weedkiller may be required to treat moss and algae growth. Internal paving can be cleaned using a mild detergent and warm water.

FLEXIBLE PAVING

In the 1970's the long practiced continental technique of flexible paving came to the UK. It has grown strongly since then and has now become the most widely used method of laying clay pavers.

The method of constructing a flexible pavement is straightforward. Pavers are placed upon a bed of uniform thick sharp sand within form edge restraints, over a prepared, sub-base. Sand is brushed into the joints and the paved construction is compacted by several passes of vibrating plate compactor.



Blue Diamond Chequer Pavers laid in $\frac{1}{3}$ running bond with Blue Ribbed Pavers and Blue 2 Panel Pavers at Camden Lock, London.

The stability of paved areas is provided by frictional restraint of the sand grains in the joints. Applied loads on one paver are transferred to adjacent pavers; an effect known as interlock.

Their speed of construction and their ability to be trafficked immediately upon completion make them popular with specifiers and contractors alike. Flexible clay pavements can withstand heavy traffic loadings and are resistant to contaminants.

Flexible clay pavements provide excellent long term performance when care is taken in the structural design and construction of the underlying layers and the wearing surface. Reference should be made to BS7533 -2: 2001 Guide for the structural design of lightly trafficked pavements constructed of clay pavers or precast concrete paving blocks and BS7533 - 3: Part3: 1997 Method for Construction of Pavements. If excavation is required, such as laying of cables, pavers can be uplifted and reinstated once the work has been completed.

Clay pavers out perform concrete block pavements because they have a permanent through colour which does not fade. Clay pavers can also shrug off stains. In trafficked locations tests indicate that a 65mm thick clay paver will perform in an equivalent manner to an 80mm concrete block.

SUB-BASE DESIGN

The thickness of the sub-base is dependent upon the type and amount of traffic to be carried by the paved area, and the likelihood of the underlying subgrade to deform in use. To establish this factor a knowledge of the Californian Bearing Ratio (CBR) is necessary. Reference should be made to BS 7533 parts 1 & 2.

If the sub-base is likely to be prone to frost then the sub-base should be adjusted to give a total pavement thickness of not less than 450mm. Wherever practicable the water table should be prevented from rising to within 600mm of the pavement surface. This can usually be achieved with the installation of subsoil drainage. The sub-base drain should be laid at low points below the level of the sub-base and perforated or open jointed pipes should be used. These should then be wrapped with a suitable filter fabric known as geotextile.

Where there is no roadbase, the surface of the compacted sub-base should be close textured to prevent migration of sand from the bedding course. It may be necessary to use "binding" materials to achieve this. The final compaction of the sub-base should be in accordance with the recommendations of BS 7533.

ROADBASE DESIGN

For lightly trafficked paved areas a roadbase is not normally required, provided that they are not expected to carry more than 0.5 million standard axles over their design life.

Where vehicle use is greater than this, or if the paved area is subject to channelised or constantly turning traffic then a roadbase should be constructed in accordance with BS 7533 - 2.

BS7533: 2001 requires that the roadbase should be levelled so that its surface level does not differ from the design level by $\pm 15\text{mm}$.

THE BEDDING COURSE

There are two main methods of constructing the sand bedding course, precompaction and compaction after placing the pavers. It is now widely accepted that the precompaction method should be used.

For each site the bedding course sand should be obtained from a single source in order to maintain consistency. If the sand is stored it should be sheeted, to prevent saturation and to help maintain a uniform moisture content.

A method of laying the bedding course is as follows:-

1. The suitability of the road base or sub base should be checked. Consideration should be given to the use of waterproofing or overlay with a suitable geotextile.
2. Sand is spread in a loose uncompacted layer.
3. Screeding boards or rails are set up on site and the area is roughly screeded to a depth of 40-50mm.
4. The sand bedding course is then compacted with two to three passes of a vibrator. The thickness of the uncompacted sand to achieve the finished surface profile after compaction needs to be established by trial and error at the start of the operation. As a guideline the uncompacted layer of sand will be approximately 15mm more than the desired finished compacted thickness. When compacted the bedding course sand should ideally be 30-35mm and no more than 50mm.
5. After initial compaction a further thin layer of sand of approximately 10mm is placed and screeded. This provides a loose surface on which the clay pavers can be placed.

It is recommended that at the end of the working day, the boundary of bedding course sand left should not exceed one metre beyond the laying course.



Blue Plain Chamfered Pavers laid in herringbone bond at the Lowry Centre, Manchester.

PAVER LAYING

It is useful to plan the layout of pavers before full scale laying begins. It may help to minimise the number of pavers that need to be cut. It will help to identify the likely sand surcharge needed in setting levels. It will also indicate the likely finished appearance and the standard of on-site workmanship.

Clay pavers should be laid by hand, commencing from a straight starting edge on the prepared bedding course. They should be laid slightly open to provide a finished joint width between pavers of approx 2-5mm beyond the edge protection nibs to permit infill and to minimise damage in compaction and subsequent use. Failure to do this may result in chipping of the clay pavers. Ketley pavers can be supplied with or without nibs. (Please note the nibs are there for edge protection of the pavers and are not spacer nibs, therefore the nibs should not be used to determine the gaps between pavers).

If deviation from the bond pattern does occur, the pavers can be adjusted to open the joints to about 5mm. This process is known as gapping. A small percentage outside this figure will not affect paver performance.

When a 90° herringbone bond pattern is used, a string line should be set up at right angles to the starting edge, and a “nose” of paving can then be advanced along it. When laying 45° herringbone pattern the laying face should develop parallel to the starting edge.

1. Pavers should be selected from three or more packs to ensure a thorough mix. If stocks of new pavers have to be laid on new work, they should be stacked about one metre back from the leading laid edge.
2. As far as possible whole pavers should be used. Pieces of less than 1/3rd of a full paver should be avoided. Various items in the Ketley range of paver fittings overcome this problem (see p.11). Infilling of boundaries and obstructions should be completed before vibration commences. Paver cutting should be carried out by a disc cutter, not by the use of a splitting machine or hammer and chisel.

It is important to check the pattern of pavers against string lines as work progresses and adjust as necessary.

Once a sufficient area of clay pavers has been placed, approximately 40m² on larger sites, fine dry sand should be brushed into the joints.

After brushing into the joints, surplus sand should be brushed away before compaction begins. Pavers should then be compacted into position by two or three passes of a vibrating plate compactor fitted with a neoprene pad. As recommended in BS7533, the plate area should be at least 0.20m². It should transmit an effective force of 50-75 kn/m² at a vibration frequency of between 60-100Hz. Compaction should not be performed closer than one metre from any unrestrained edge.



Blue Chamfered Pavers and Kerb Units - Wellingborough.

Further sand should then be applied and the procedure repeated. After final compaction 1-2mm of sand can be spread over the paved area to promote joint fitting and to fill any voids which may develop.

Commencement of use of the pavement may need to be delayed if the bedding course is saturated following heavy rain. During the early life of the pavement there is likely to be some settlement of sand within the joints. Therefore the site should be monitored and arrangements made for further sand to be brushed in, to top up the joints.

EDGE RESTRAINTS FOR PAVED AREAS

Rigid edge restraints must be provided for all flexible clay paved areas. Edge restraints protect against the loss of bedding course material and restrict pavers from lateral movement.

Edge restraints can be provided either by existing features such as walls or concrete slabs, or by purpose made kerb fittings (see p.12,13).

They should be adequate to support overriding by traffic. Concrete haunching should be provided at the rear of the edge restraint in order to resist lateral movement. No haunching should be provided to the front of the edge restraint.

Concrete must be properly set before vibration of the pavers. Movement joints should be provided at approximately six metre centres using the line of edge restraint.

If the edge restraint is required to be hidden, a temporary timber support should be used which can be replaced by a concrete bund after the pavers have been fully compacted. This should be recessed below the level of the clay pavers in order to permit subsequent landscaping to hide the restraint.

TEMPORARY EDGE RESTRAINT

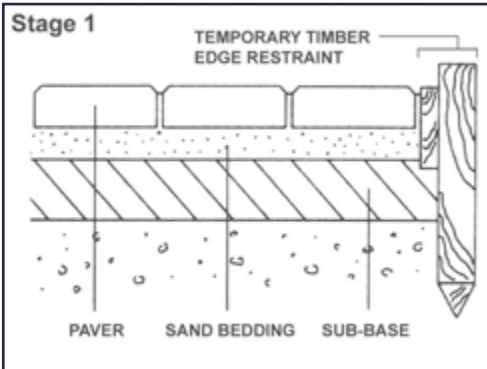

ACCESS COVERS

The siting of inspection covers is important to preserve the aesthetics of a paved area. Covers must be sited with some care, located within an area of paving and aligned with the pattern. They should not straddle different colours or patterns.

Recessed covers inserted with matching pavers are desirable as they are less intrusive although it is likely that pavers will need to be cut to fit. In rigid paved areas movement joints should be provided around covers.

GRADIENTS

As a general guide, flexible pavements can be laid to a maximum slope of 1 in 10. For steeper gradients rigid paving should be used. Paver laying should always commence at the bottom of the gradient and provision for bedding course drainage should be made at this point. For gradients in excess of 1 : 20 consideration should be given to the use of an acrylic pre polymer to prevent the wash out of jointing sand. It may be necessary to break up flexible paving into shorter lengths, say 10m on slopes with the use of rigid restraints, in order to prevent the creeping action of pavers and sand down the slope.

STEPS

Riser height of steps is usually between 100 - 175mm. Each step should feature a fall to the nose - approximately 6mm to clear surface water. Experience suggests that the square edges of standard bricks are vulnerable to damage and that large radius bullnose bricks are not recommended from a safety viewpoint. Therefore the Ketley specials range includes a tight radius nosing as a special feature for steps.

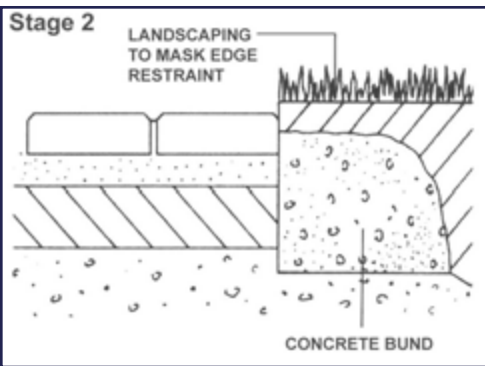

ADDITIONAL LAYING REQUIREMENTS

DRAINAGE

All types of paver installation need effective drainage for surface water. To achieve a satisfactory run off it is recommended that longitudinal gradients should not be less than 1 : 100, and that cross falls should be approximately 1 : 40.

For large areas of pavements it may be necessary to include drainage provision within the pavement itself. Ketley provide drainage units which are compatible with standard metal gully outlets.

Flexible pavements may allow water to penetrate the surface and therefore consideration should be given to drainage of the underlying formation. Drainage of the bedding course can be achieved by sub-base drains which should be laid at the low points below the level of the sub-base using perforated or open joint pipes. A free draining geotextile should be used to prevent the loss of bedding sand.

POST LAYING CARE

In the immediate period following paver laying it is usual for there to be settlement of sand within the joints. The site needs to be monitored and further sand should be brushed in as a "top-up" to the joints. Vacuum road sweepers should not be used during the early life of the pavement as they will remove the jointing sand.

In situations where an excessive amount of grime and dirt has built up, occasional steam cleaning should be carried out. Jointing sand levels should be checked after this operation and replaced as required.

Pavements in damp areas such as beneath trees and in permanent shade may develop unwanted weed or moss growth. A proprietary weedkiller should be used which will have no detrimental effect on the pavers.

BOND PATTERNS

The bond pattern and its direction are important both to the visual appearance and the performance of the paved area. It is therefore crucial that the bond pattern is considered at the design stage of the project. The use of two or more contrasting colours within the paved area presents further design opportunities, and can highlight the chosen bond pattern.



HERRINGBONE BOND

This is the recommended pattern for areas used by vehicular traffic. It resists creeping caused by braking or channelised traffic flow. Both 90° and 45° orientation to the starting edge and direction of the traffic is suitable, but 45° is generally preferable for heavy vehicle areas. Ketley can provide purpose made starter units for both patterns. It is preferable to use purpose made half units for 90° herringbone, since pavers cut on site will have no chamfer on the cut edge. This bond has the visual effect of increasing the perceived size of an area.



BASKET WEAVE

The basket weave pattern accentuates straight lines, and great care through the constant use of string lines is necessary to prevent misalignment. This bond pattern is only recommended for pedestrian use. It reduces the perceived size of an area.



RUNNING BOND

The pattern is suitable for areas which are going to be used by pedestrians and area receiving light or occasional trafficking, such as domestic driveways. Where vehicular traffic is expected it is recommended that the long axis of the paver is placed at 90° to the traffic flow direction, and it will be more pleasing to the eye laid in this manner. All Ketley pavers can be laid at half bond, with the exception of Diamond Chequer which should be laid at third bond in order to maintain the pattern throughout the paved area.



STACK BOND

This pattern is only suitable for pedestrian use. It has strong linear characteristics in two directions. It requires greater dimensional consistency of pavers and a regular checking of string lines to ensure maintenance of the bond.

PATTERNED PAVERS

Ketley chequered and panelled pavers are traditional products. Widely used by the Victorians beside their canal and railway systems and in their industrial and urban developments, they have undergone and passed the ultimate test - the test of time.

Their continuing popularity lies in their strength, durability, chemical and abrasion resistance and lasting colour whilst their patterned surface not only sheds water rapidly and provides enhanced traction but adds to their interest and aesthetic appeal. Ketley patterned pavers are suitable for providing contrasting banding within large areas of other less attractive material.

LAYING CONSIDERATIONS FOR PATTERNED PAVERS

To derive the full aesthetic impact from patterned pavers it is important that care is taken when laying. Ketley patterned pavers have nibs on 4 sides. When laid in the flexible mode these should be spaced apart 2-5mm beyond the nibs to permit sand infill and to minimise damage in compaction and subsequent use.

The regular use of string lines is recommended in order to check for paver alignment. Adjustments to the joints should be carried out with the use of a trowel. The occasional wider joint is not detrimental to performance.

DIAMOND CHEQUER PAVER (SQUARE EDGED)



To maintain the pattern throughout the paved area Ketley Diamond Chequer Pavers should be laid $\frac{1}{3}$ bond, rather than $\frac{1}{2}$ bond, which is the standard bond for Plain Pavers.

8 PANEL PAVER (CHAMFERED)



2 PANEL PAVER (CHAMFERED)



GROUP PT TACTILE PAVER UNITS

Tactile pavers are designed to provide visually handicapped pedestrians with an easily detectable indicator underfoot.

Blister pattern pavers conform to the Department of Transport Guidance on the use of tactile paving surfaces. The use of dropped kerbs and tactile surfaces at pedestrian crossing points.

They have a work size of 200 x 133mm. There are 37.6 per m². They are available in Red and Blue.

PT.1.0
Tactile blister paver

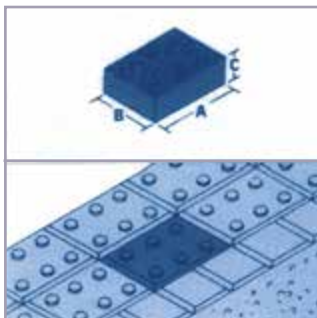

▲	A	B	C
mm	200	133	65

PT.2.0 Tactile platform edge (Blister) paver

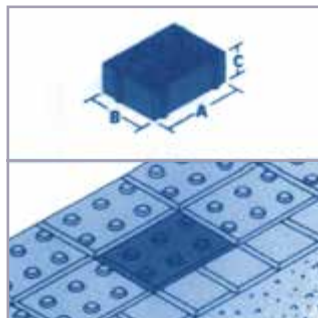

▲	A	B	C
mm	200	133	65



Blue Tactile Blister Pavers in Hammersmith, London.

PT.3.0
Tactile ribbed/corduroy

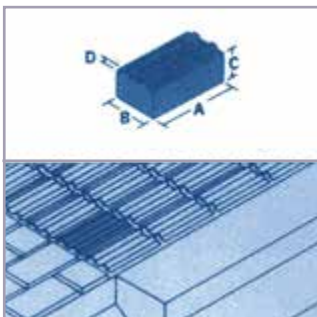

▲	A	B	C	D
mm	200	100	65	6

PT.4.0
Directional paver

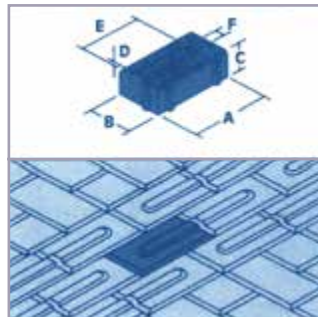

▲	A	B	C	D	E	F
mm	200	100	65	6	165	35

Ribbed or corduroy pavers comply with Building Regulations Approved Document M - Access and facilities for disabled people, and are used to indicate the proximity of a hazard in the footway e.g. steps or an escalator. They are placed at the top of steps and provide a tactile warning.

Directional Pavers are non standard units and are laid "back to back" as shown in the diagram.

GROUP PS STARTER UNITS

PS.1.0
Half Paver

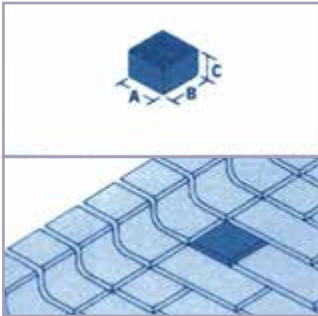

▲	A	B	C
mm	100	100	65

PS.2.0
Square block

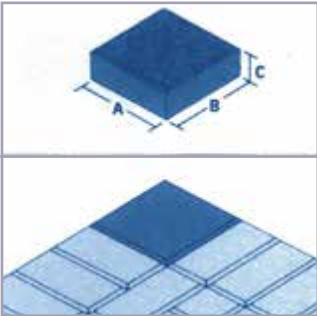

▲	A	B	C
mm	200	200	65

50MM STARTER UNITS ARE AVAILABLE TO MATCH 50MM PAVERS



PS.3.0
Small Triangle

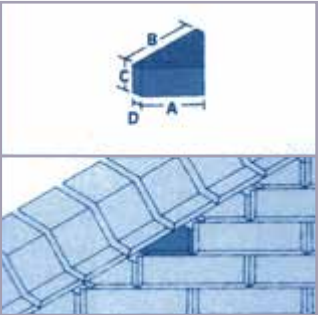

▲	A	B	C	D
mm	100	138	65	25

PS.4.0
Bishops mitre

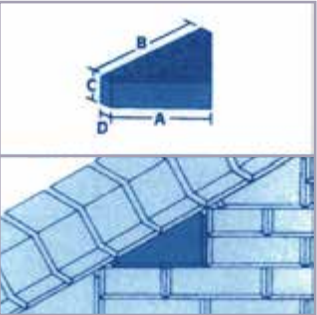

▲	A	B	C	D
mm	200	280	65	25



Blue standard kerbs and small triangle starter units with red pavers laid in 45° herringbone bond.

Tactile ribbed/corduroy pavers are used here to mark the limit of the paving area and warn of the drainage channel on this eco-development site in Sweden

GROUP PK KERB UNITS

PK.1.0
Standard Kerb

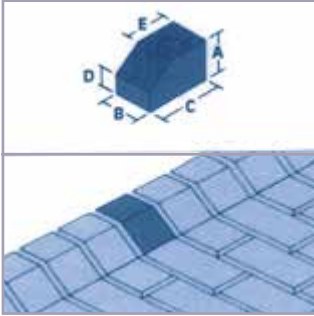

▲	A	B	C	D	E
mm	125	100	160	65	100

PK.1.1
Standard Kerb external return

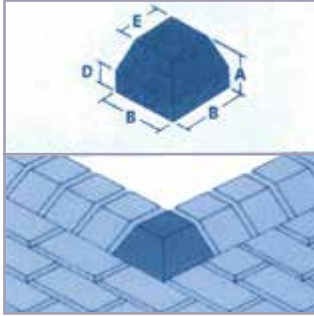

▲	A	B	C	D	E
mm	125	160	160	65	100

PK.1.2
Standard Kerb internal return

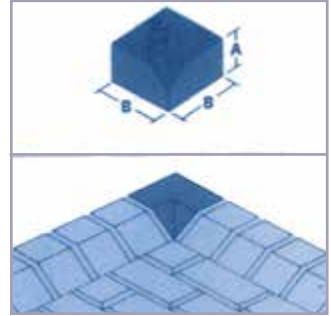

▲	A	B	C	D
mm	125	160	160	60

PK.2.0
Step Kerb

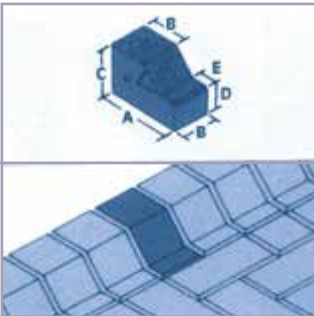

▲	A	B	C	D	E	α
mm	200	100	125	65	40	45°

PK.2.1
Step Kerb external return

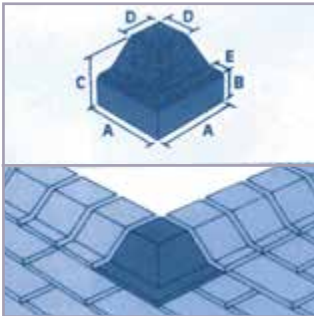

▲	A	B	C	D	E
mm	200	65	125	100	40

PK.2.2
Step Kerb internal return

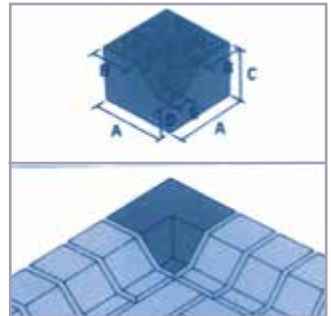

▲	A	B	C	D	E
mm	200	100	125	65	40

PK.3.0
Step Kerb (laid on end)

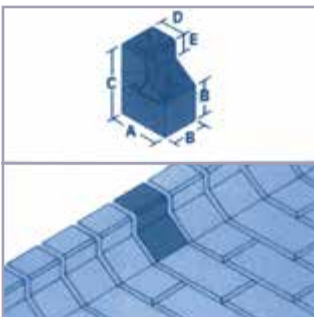

▲	A	B	C	D	E	α
mm	125	100	200	65	40	45°

PK.3.1
Step Kerb (on end) external return

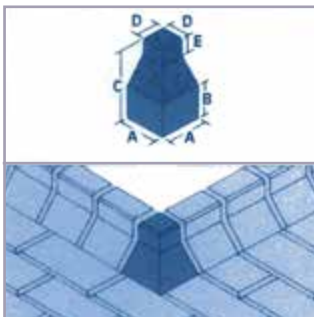

▲	A	B	C	D	E
mm	125	100	200	65	40

PK.3.2
Step Kerb (on end) internal return

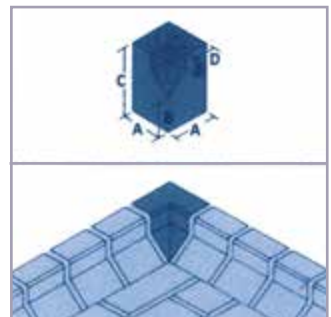

▲	A	B	C	D	E
mm	125	100	200	65	40

GROUP PK KERB UNITS

PK.4.0
Bullnose Kerb

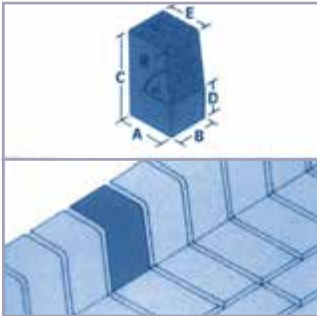

▲	A	B	C	D	E	R	α
mm	125	100	200	65	94	25	77°

PK.4.1
Bullnose Kerb external return

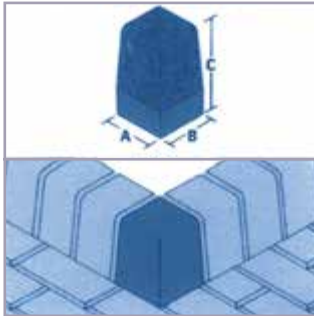

▲	A	B	C
mm	125	125	200

PK.4.2
Bullnose Kerb internal return

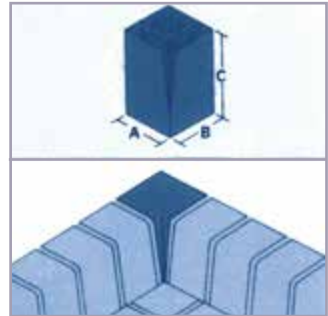

▲	A	B	C
mm	125	125	200

PK.5.0
Boot Kerb

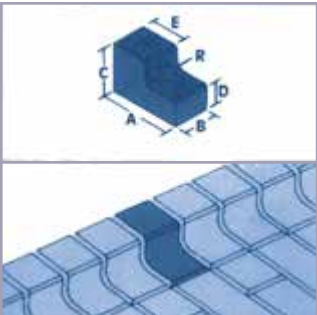

▲	A	B	C	D	E	R
mm	200	100	125	65	100	25

PK.5.1
Boot Kerb external return

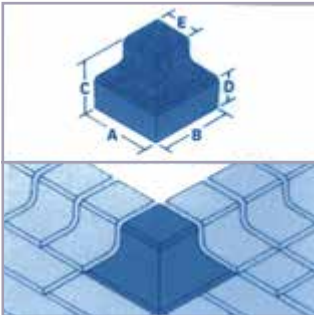

▲	A	B	C	D	E
mm	200	200	125	65	100

PK.5.2
Boot Kerb internal return

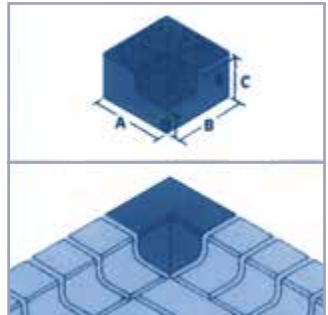

▲	A	B	C	D	E
mm	200	200	125	65	100



Ketley blue boot kerbs with Ketley 2 panel pavers.

GROUP PD DRAINAGE UNITS

PD.1.0
Drainage channel

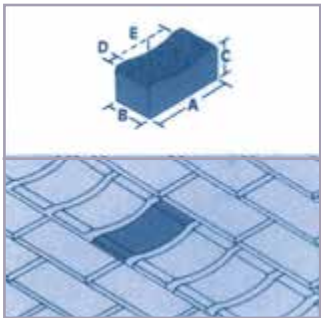

▲	A	B	C	D	E
mm	200	100	65	25	9

PD.2.0
Drainage channel stop end

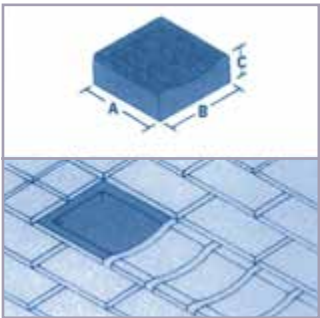

▲	A	B	C
mm	200	200	65

PD.3.0
Drainage channel 90° return

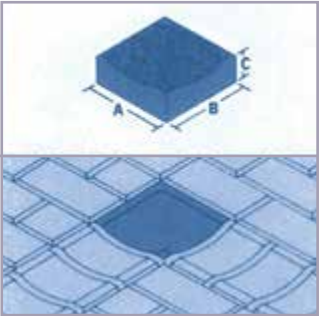

▲	A	B	C
mm	200	200	65

PD.4.0
Drainage channel 'T' junction

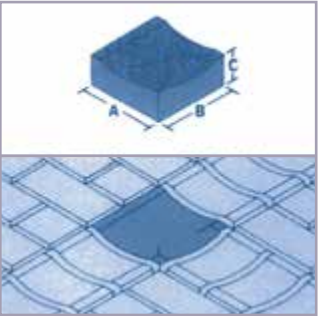

▲	A	B	C
mm	200	200	65



Ketley drainage channels with Ketley 2 panel pavers.



Blue drainage units with red pavers laid running bond.

GROUP PTR TRANSITION UNITS

PTR.1.0
Transition unit

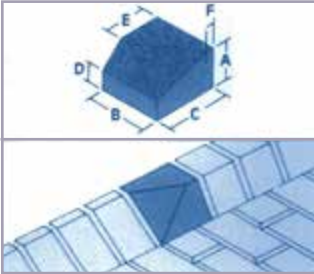

▲	A	B	C	D	E	F
mm	125	160	160	65	100	20

PTR.2.0
Crossover unit

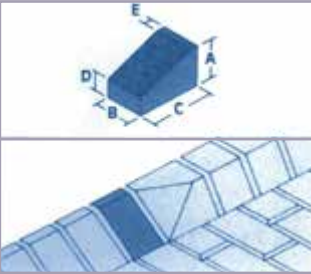

▲	A	B	C	D	E
mm	125	100	160	65	20

PURPOSE LAID CANT KERB
Transition set

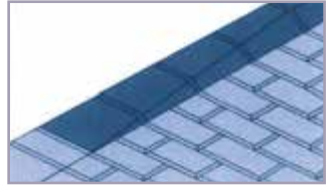

GROUP PST STEP PAVER UNITS

PST.1.0
Step paver

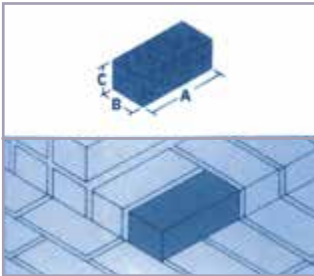

▲	A	B	C	PST
mm	215	103	65	1.0
mm	200	100	50	1.1
mm	200	100	65	1.2

PST.2.0
Step header

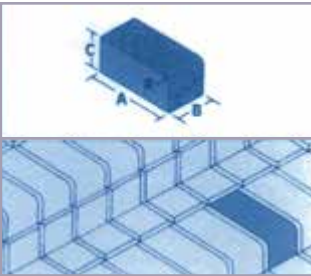

▲	A	B	C	R	PST
mm	215	103	65	25	2.0
mm	200	100	50	7	2.1
mm	200	100	65	7	2.2

PST.3.0
Step stretcher

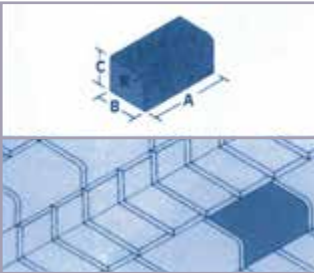

▲	A	B	C	R	PST
mm	215	103	65	25	3.0
mm	200	100	50	7	3.1
mm	200	100	65	7	3.2

PST.4.0
Step corner return

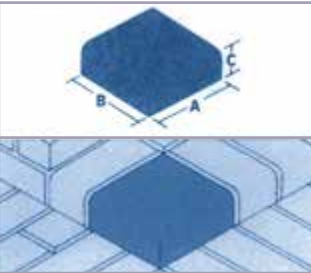

▲	A	B	C	R	PST
mm	215	103	65	25	4.1
mm	200	200	50	7	4.2
mm	200	200	65	7	4.3

GROUP PDT

DETERRENT PAVER

Typically used to deter use by pedestrians, bicycles or vehicle over-run. Deterrent pavers and standard pavers are often laid in alternative rows as shown below. They should be laid mindful of the likelihood of over-run. In long rigid runs movement joints are required typically at 6m centres. Other deterrent pavers can be manufactured on request.

PDT.1.0
Deterrent paver

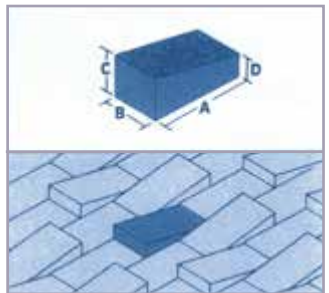

▲	A	B	C	D
mm	200	100	90	50

PLAIN AND PATTERNED PAVER SPECIFICATIONS

Colour: Staffordshire Blue, Red and Brown Brindle
Finish: Dragfaced or Patterned
Raw Material: Etruria Marl
Manufacture: Extruded, Wirecut and fired above 1130°C
Bulk Density: 2,300 kg/m³

Performance Data:
 BS EN 1344 : 2002

Size Range	R1
Mean transverse Breaking load	T4
Unpolished slip/skid resistance	U3
Abrasion resistance	A3
Freeze/thaw resistance	FP100

Plain Dragfaced Pavers

Sizes and Coverage

Work Size mm	Pattern	Pack Weight	No. Per Pallet	Units per m ²	
				Rigid with 10mm Joint	Flexible Butt Jointed (3mm Joint)
215x102.5x50	Square Edged	1300kg	500	40	44
215x102.5x65	Square Edged	1320kg	400	40	44
200x100x50	Square Edged & Chamfered	1150kg	500	43	48
200x100x65	Square Edged & Chamfered	1200kg	400	43	48

Patterned Staffordshire Pavers

Sizes and Coverage

Work Size mm	Pattern	Pack Weight	No. Per Pallet	Units per m ²	
				Rigid with 10mm Joint	Flexible Butt Jointed (3mm Joint)
220 x 105 x 50	Diam Cheq/2 or 8 panel	1300kg	500	38	42
220 x 105 x 65	Diam Cheq/2 or 8 panel	1360kg	400	38	42
200 x 100 x 50	Diam Cheq/Star/2 or 8 panel	1150kg	500	43	48
200 x 100 x 65	Diam Cheq/Star/2 or 8 panel	1200kg	400	43	48

Ketley Quarry Tiles



Ketley Quarry Tiles, sometimes known as paving tiles, are available in a range of natural clay colours, and offer similar performance to traditional quarry tiles. They offer excellent slip resistance (R11 and suit Category C which are the highest ratings for slip resistance according to BS EN 14411) and are suitable for most flooring and wall cladding applications indoors or externally, in commercial premises or the home.

LAYING QUARRY TILES

Quarry tiles should only be laid on a rigid bed with no voids underneath so the load applied to them is transferred through to the base. In situations where heavy loads are involved the strength of the installation can be improved by the use of a thicker paver as the transverse breaking load of a clay paving product is directly related to its thickness where all other factors are equal. It is advisable to select the material to resist the most arduous conditions likely to be imposed during the life of the product.

GROUTING

Grouting of Quarry tiles laid with wet cement-sand mortars or adhesives should not be carried out for 12 hours after laying the quarry tiles. Where a semi-dry mix method is used, tiles should be grouted within 4 hours of laying to ensure a full bond between the grout and the bedding.

Board should be laid over the tiled area to spread the load of the tiler when carrying out the grouting operation. The grouting mortar should be adapted for the width of the joint with a lower ratio of cement for wider joints. A mixture of 1:1 cement to fine dry sand by volume mixed to a paste with only the minimum of water for workability, should be used for joints of less than 3mm and a ratio of 1:3 for joints wider than 6mm. Avoid too wet a mix, as this will dry out rapidly and the grouting will crack and break out. Work in the grout in small joints with a squeegee action. In wider joints pointing is recommended. After the joints have been filled, scatter a dry 1:3 or 4 mortar mix over the joints: allow to dry for about 5 to 10 minutes, then brush away excess loose material with a soft bristle brush. Finally clean off the tiles with water and a cloth, avoid excess watering of the tiles in this operation.

If an impervious joint is required, additives may be used in the grout mix or proprietary ready grouts can be used. However advice should be sought from the manufacturers as to their suitability for the application. Attention should be paid to cleaning any proprietary grout or grouts mixed with additives off the surface of the Quarry tiles immediately.

Tiles should be cleaned as work proceeds. Such cleaning should be minimal with good workmanship.

CLEANING

Under normal circumstances Quarry Tiles require little maintenance and can be kept clean by sweeping then washing with warm water to which a suitable non-soapy detergent has been added.

Clean and dry flooring surfaces possess a low slip potential, the majority of slip accidents occur in the presence of a contamination between the floor surface and foot. The likelihood of a slip occurring is greatly reduced if contamination is controlled by means of a cleaning and maintenance procedure. In order for a cleaning and/or maintenance regime to be effective there are a number of basic elements that should be considered:

- Before establishing a floor cleaning protocol, the specific contaminants must be identified in order to enable the selection of the appropriate cleaning agent
- The cleaning tools provided should be appropriate for use with the floor in question - it may be necessary to assign dedicated tools for specific areas
- Regular cleaning of the floor should be scheduled, specifying the responsible person and time of day or night (dependent on likely volume of pedestrian traffic) cleaning should take place
- Clear instruction should be provided as to the cleaning requirements and procedures, correct use and disposal of detergents, emergency conditions and procedures and recording and reporting of maintenance operations
- Wear, damage, debris and contaminants should be identified through routine inspection of floor surfaces.

Contamination cleansing routines are dependent upon a number of factors including the type of surface to be cleaned, the contamination present, the availability of chemical cleaning agents and the practicality of manoeuvring cleaning machinery in the given space. Beyond the method used, it is imperative to ensure all contaminants are removed following the cleansing process. The freshly cleaned floor must be thoroughly rinsed with clean water to make certain that all cleaning agents are removed and the floor is dry on completion. Failure to conduct these last actions can lead to a build-up of concentrated contaminate and cleaning agent on the surface of floors. These contaminant and cleaning agent residues will combine with any water subsequently applied to form an emulsion that can spread over the floor surface, significantly increasing the slip potential.

Quarry Tiles should require only a small amount of cleaning on completion, and this only when the joints are hard. This should be done with a non-soapy, neutral, sulphate-free detergent and cleaned off with clean water. Strong detergents should not be used as they can cause scumming. Always damp tiles before applying a cleaning agent to avoid the cleaner being drawn into the body of the tile: the cleaning treatment is then restricted to the surface of the tile.

Difficult stains can be removed in one of three ways;

- By the use of an abrasive soap. Steel wool should not be used as small particles may be deposited in the grouting causing rust marks
- By chemical means, by reaction with the appropriate solvent but due to the variety of materials that may cause staining it is recommended that advice is sought from organisations such as Lucideon in Stoke on Trent.
- By bleaching to remove the colour from the stain, although this should not be done on a regular basis.

NB: The use of sealers and polishes on Quarry Tiles can make regular cleaning more difficult.

QUARRY TILE FITTINGS

KQTREL
Round Edge Long

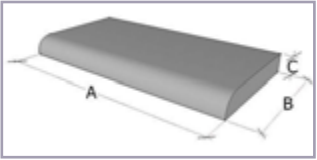

▲	A	B	C
mm	215	102.5	18
mm	215	65	18
mm	100	100	18
mm	150	150	18

KQTRES
Round Edge Short



▲	A	B	C
mm	215	102.5	18
mm	215	65	18
mm	100	100	18
mm	150	150	18

KQTREX
Double Round Edge

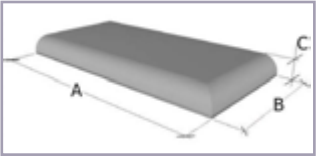

▲	A	B	C
mm	215	102.5	18
mm	215	65	18
mm	100	100	18
mm	150	150	18

KQTST
Step Tread

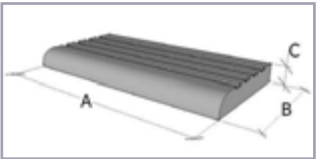

▲	A	B	C
mm	215	102.5	18

KQTCBRT
Coved based round top

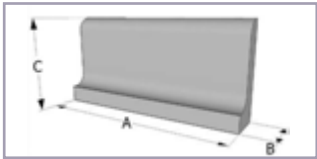

▲	A	B	C
mm	215	36	102.5

KQTCBRTX
Coved base round top external

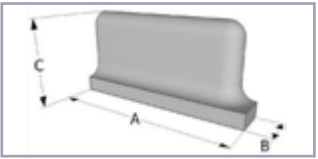

▲	A	B	C
mm	215	36	102.5

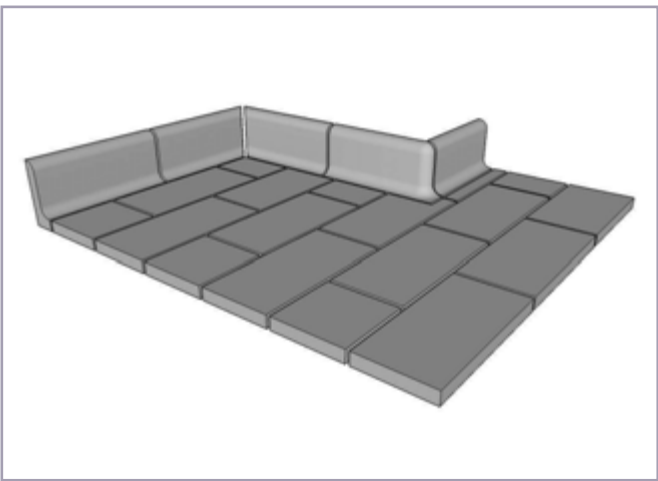

TECHNICAL SPECIFICATIONS FOR QUARRY TILES

COLOURS: Staffordshire Red / Staffordshire Light Multi / Staffordshire Dark Multi
Staffordshire Brown Brindle / Staffordshire Blue

TEXTURE: Smooth

MANUFACTURE: Extruded

REVERSE KEY: Ribbed

PROPERTIES	BS EN 14411 GROUP A1b REQUIREMENT	TYPICAL VALUES
Dimensions and surface quality		
Length x Width 215mm x 102.5mm	Average tolerance $\pm 2\%$ to an individual maximum of $\pm 4\text{mm}$	length 215mm $\pm 2.5\text{mm}$ width 102.5mm $\pm 1.5\text{mm}$
Thickness 18mm	Average tolerance is $\pm 10\%$	$\pm 1\text{mm}$ tolerance
Straightness of sides	within $\pm 0.6\%$	0.2%
Rectangularity	within $\pm 1\%$	0.2%
Surface flatness	Centre curvature $\pm 1.5\%$ Edge curvature $\pm 1.5\%$ Warpage $\pm 1.5\%$	Centre curvature $\pm 1.5\text{mm}$ Edge curvature $\pm 1\text{mm}$ Warpage $\pm 1.5\text{mm}$
Physical properties		
Water absorption	0.5 < 3%	1.50%
Breaking strength	Min 1100N	2995N
Resistance to deep abrasion	Max 275mm ³	106mm ³
Frost resistance	Value to be stated	No damage after 100 cycles
Slip resistance	Pendulum test results exceeding 36 indicate low slip potential Inclined platform in shod conditions not to be slippery in wet or greasy conditions. Inclined platform in wet barefoot conditions	Dry value av of 63 Wet value av of 55 Category R11 which indicates that they are considered
Bond strength	C2 Cementitious adhesives Reaction resin adhesives Mortar	Category C which is the highest rating for slip resistance. >1.0 N/mm ² >2.0 N/mm ² 0.15 N/mm ²
Moisture expansion	No requirement	Negligible
Reaction to fire	Value to be stated	A1
Chemical properties		
Resistance to staining	Minimum requirement 3 Chemical/oxysiding stain 4	Paste stain 5 Film stain 3

